

## PO450G3

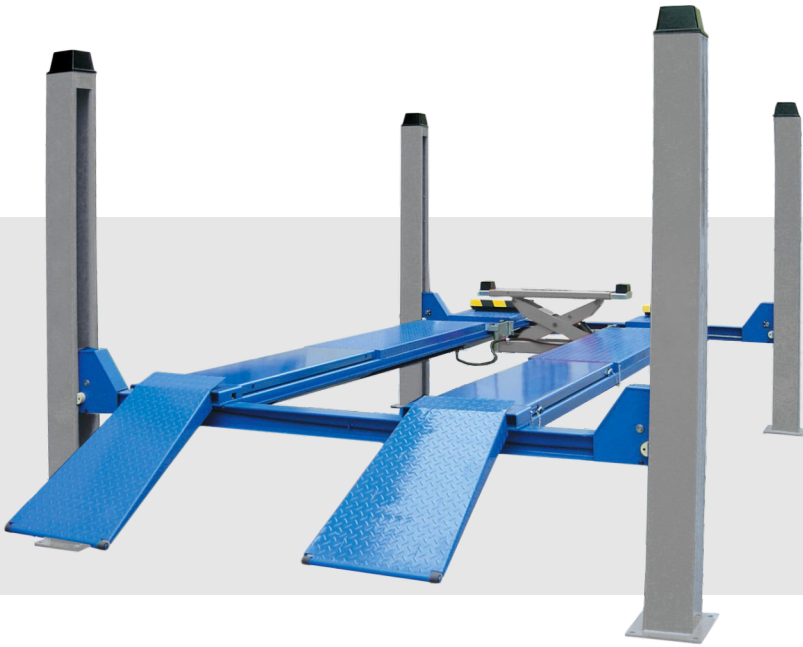

CAPACITY:	4500 kg
POWER SUPPLY:	400V/50Hz
AIR SUPPLY:	6-8 bar max.
MOTOR POWER:	2,2 kW
LIFTING HEIGHT:	1896 mm
CLEARANCE:	3000 mm
PLATFORMS:	490x5190 mm
NOISE LEVEL:	<70 dB (A)
WEIGHT:	1350 kg

### OPTIONAL EQUIPMENT

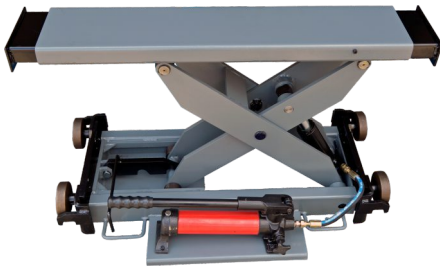

XT200H  
axis hoist 2T with manual hydraulic pump

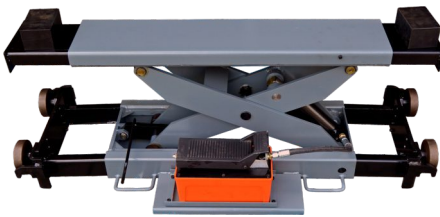

XT200P  
axis hoist 2T with hydraulic pump supplied pneumatically

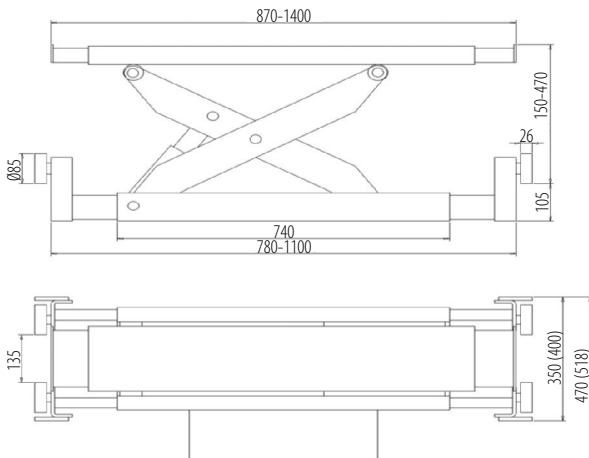

Electrohydraulic lift for geometry Platforms with grooves for turntables and expansion plates Mechanical height lock released pneumatically Adjustable position of one platform Perfectly secured hydraulic actuator

Galvanised ropes initially stretched Rope wheels with large diameter Lift lock while slackening or breaking ropes

Lift steering with safe voltage 24V Safety devices compatible with norm EN1493:2010.

